

MODELING THE COMMUNICATIONS IN AN EMERGENCY PLAN WITH P-DEVS

Cristina Ruiz-Martin^{1,2}, Gabriel A. Wainer¹, Adolfo Lopez-Paredes²

¹Carleton University
1125 Colonel By Dr
Ottawa, K1S5B6, CANADA

²Universidad de Valladolid
Paseo del Cauce 59
Valladolid, 47011, SPAIN

ABSTRACT

Recent disasters reveal that current emergency plans are not enough robust to treat this situations. Doing real life simulacrum to test some aspects of the emergency plans causes the stagnation of the normal work in the organizations and they carry high costs. Simulation tools are a affordable way to deal with these tests. In this work, we use P-DEVS to test the communication system in a nuclear emergency plan.

1 INTRODUCTION

Recent disasters such as the accident at TEPCO's Fukushima nuclear power plant in 2011 or the Hurricane Katrina in 2005 prove that these events can no longer be considered improbable situations.

Some works remark the importance of communication and management systems in crises and states that improvements are needed in this field (Omoto, 2013), (Langlois, 2013). Doing real life simulacrum to test some aspects of the emergency plans, such as the robustness of the communication system, cause the stagnation of the normal work in the organizations, take long time and they also carry high costs. Modeling and simulation techniques deal with these problems providing a cost effective way of doing those tests without affecting the normal work in the organizations.

The objective of this research is to provide a cost-effective way to improve the robustness of emergency plans. In this work, we model and simulate the communication system of a real nuclear emergency plan (NEP) using P-DEVS to analyze the robustness of the NEP in terms of its communication system.

2 RELATED WORK

A review of the literature shows that there are not tools to test the resilience of emergency plans in terms of communication systems and management in a cost-effective way.

In our previous research (Ruiz-Martin et al., 2014), we built the theoretical model of the NEP using the information provided by one of the persons responsible for this NEP in Spain. We also formalized the model using Network Theory and we analyzed the characteristics and properties of the communication and command chain network established in the emergency plan.

Following this work, in (Ruiz-Martin et al., 2015) we analyzed the resilience of the NEP against a downfall in different communication channels and in different scenarios without considering the dynamics of the network.

The communications during an emergency are discrete messages between people sent through different communication mechanisms and networks. DEVS is a powerful framework to simulate discrete event systems. Therefore, it will be the framework used to model and simulate the communications in the NEP.

3 P-DEVS MODEL

As discussed in section 1, our objective is to provide a cost-effective way to improve the robustness of emergency plans. For this purpose, continuing the work in (Ruiz-Martin et al., 2015) we build a P-DEVS

model to simulate the communications handle while dealing with a nuclear emergency as stated in the NEP under case study.

In the model, we have four main types of components (figure 1):

1. **SQL Database.** The SQL Database is where all the information related to the behavior of people is stored.
2. **Person.** Person coupled model represents a person and its behavior in the emergency regarding to information transmission and reception.
3. **Communication device type “x”.** This coupled model represents the communication devices used by the people in the emergency to send and receive information. This model can be a phone, a radio, a fax, etc.
4. **Network type “X”.** This coupled model represents the communication networks that use the different devices to send and receive the information to and from other devices. This model can be a line phone network, a wireless network, a radio channel, etc.

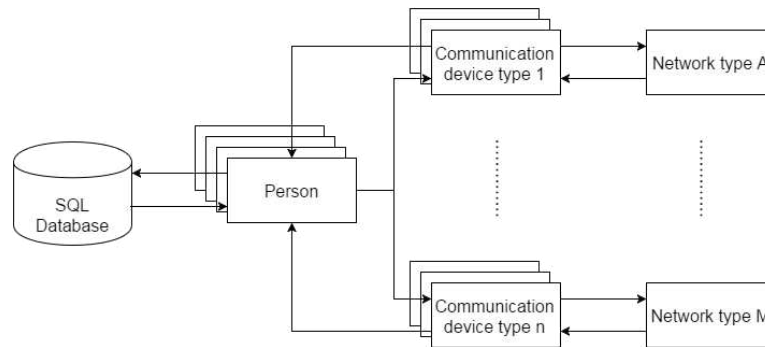

Figure 1. Components of the P-DEVs model

4 CONCLUSIONS

In this work, we demonstrate that it is possible to simulate and test the communications in emergency plans using modeling and simulation tools, specifically, the DEVs framework. Using DEVs, we can study how different failures in the communication channels or communication devices affect the communications during an emergency or how the behavior of people involved also affect the information transmission.

ACKNOWLEDGEMENTS

This research has been partially supported by NSERC and University of Valladolid.

REFERENCES

- Langlois L. (2013). IAEA action plan on nuclear safety. *Energy Strategy Reviews* 1(4):302-6
- Omoto A. (2013). The accident at TEPCO's Fukushima-Daiichi Nuclear Power Station: What went wrong and what lessons are universal? *Nuclear Instruments and Methods in Physics Research Section A: Accelerators, Spectrometers, Detectors and Associated Equipment*, 731: 3-7.
- Ruiz-Martin C., Ramirez-Ferrero M., Gonzalez-Alvarez J. L. and Lopez-Paredes A. (2015). Modelling of a Nuclear Emergency Plan: Communication Management. *Human and Ecological Risk Assessment: An International Journal* 21(5):1152-1168
- Ruiz-Martin C., López-Paredes A., Wainer G. (2015) Applying Complex Network Theory to the Assessment of Organizational Resilience. *Proceedings in Information Control Problems in Manufacturing 2015 (INCOM 2015)* (in press)