

## **HYBRID SIMULATION OF RENEWABLE ENERGY GENERATION AND STORAGE GRIDS**

Peter Bazan  
Reinhard German

Friedrich-Alexander-Universität Erlangen Nürnberg  
Martensstr. 3  
D-91052 Erlangen, GERMANY

### **ABSTRACT**

The share of renewable energy sources in energy production is growing steadily. Domestic homes can be equipped with solar panels, micro combined heat and power systems, batteries, and they can become adaptive consumers. They can also deliver energy to the grid and react to the energy supply. This paper presents a hybrid simulation approach for the analysis of a grid of domestic homes equipped with different technological options with respect to efficiency and costs. For energy storage and energy flows the system dynamics modeling paradigm is used whereas control decisions are modeled as statecharts. The highly intermittent solar irradiation and also the electric power and heat demands are implemented as stochastic models. The component-based design allows for quick creation of new case studies. As examples, different homes with batteries, micro combined heat and power systems, or energy carrier carbazole as energy storage are analyzed.

### **1 INTRODUCTION**

In the transformation of the traditional energy system towards a more sustainable system it is commonly assumed that decentralized approaches will play a dominant role. To achieve this goal, various technological possibilities have been suggested. Choosing the right option becomes very difficult even for a single household but also on a larger scale, e.g., for national economies and related incentive systems. Relevant technologies comprise photovoltaics and wind turbines for a completely regenerative but volatile generation as well as micro combined heat and power systems based on, e.g., motors or fuel cells. Storage of energy is possible in water tanks for heat and in batteries for electricity. Furthermore, liquid carriers such as carbazole have been suggested (Teichmann et al. 2011), which is similar to Diesel and can bind hydrogen at very good densities, leading to much larger storage capacities than batteries. To utilize carbazole as an energy storage, a fuel cell and catalyzers are required and at the hydrogenation of the liquid heat is produced, whereas for dehydrogenation heat is required. In all cases heat and power must be considered together in order to find efficient and profitable solutions. Additional degrees of freedom arise when houses with regenerative technologies cooperate.

In this paper a flexible simulation framework is proposed in order to investigate such energy systems. For this purpose, basic components of decentralized energy systems are provided which can be connected in various ways. The basic components describe solar modules (as typically installed on house roofs) together with a stochastic model of fluctuating solar insolation, gas burners and water tanks as needed for conventional heating, micro combined heat and power systems based on fuel cells, batteries as well as carbazole storages. Two further basic components represent stochastic models of electricity and heat demand in typical European households. The basic components are then combined in order to form three prototype regenerative houses: a “battery house” (with a solar module, a battery and a conventional gas heating), a “ $\mu$ CHP house” (with a solar module, a battery and micro combined heat and power), and a

“carbazole house” (with a solar module and a large carbazole storage and an additional conventional heating when the heat of the hydrogenation is insufficient). Based on further assumptions for energy prices (both for gas and electricity, electricity can be purchased from the net and sold to it) one can study the interaction of these systems (e.g., fillings of the storages, power supply and demand curves, power import and export etc.) and one can also derive metrics about efficiency and possible costs or profits of the different houses on the long run.

We also examine a scenario in which such houses and a solar park cooperate in order to come close to self-sufficiency (with respect to electricity and gas) and to maximize the possible profit. All three types of houses are replicated (with individual electricity and heat demands) and cooperate in a storage grid. First houses try to stay self-sufficient (with respect to electricity) by using the supply from their solar module and their storage (battery or carbazole). If this is not possible, they first try to get electricity from inside the storage grid (supply from the solar modules of the other houses or the solar park or from a battery or carbazole storage) at a price below the normal price in the electricity net, otherwise electricity must be purchased from the normal electricity net. Free supply (i.e., supply from a solar module of a house exceeding its demand and which cannot be stored in that house and supply from the solar park exceeding the demands of all houses) is first put in the storages of the houses for free (!) and is otherwise sold to the surrounding net. For all prices close-to reality prices in the German market and regulation system are assumed. It turns out that all houses can profit significantly from the cooperation compared with the operation as a single house.

The model is a hybrid simulation model: continuous processes such as energy flows are represented by system dynamics (SD) models. Control decisions and fluctuations such as weather and load are represented by discrete event models. We apply the simulation software AnyLogic (XJ Technologies Company Ltd. 2012) which allows to combine SD and discrete–event modeling in one framework. Components are active objects with internal SD and discrete event parts and can be dynamically connected at run-time, leading to a “dynamic system dynamics” approach, which provides flexibility in connecting arrays of components without the need of manual replication of the SD elements of the system, as would normally be the case.

A main contribution of the paper is first the modeling approach for components of regenerative energy systems including the “dynamic system dynamics” approach which allows for a flexible composition of larger models. A second contribution is the investigation of the dynamics of volatile generation, volatile demands (both electricity and heat) in combination with storage technologies in single houses, especially with storage based on liquid carriers. A third contribution is the study of the cooperation of several of such houses in a storage grid leading to significant benefits.

The rest of the paper is organized as follows. In Ch. 2 related work is discussed, Ch. 3 explains the basic concepts of the simulation approach, Ch. 4 then shows the models of the basic components which are connected to houses in Ch. 5 and in turn to grids in Ch. 6. Ch. 7 concludes the paper.

## **2 RELATED WORK**

A hybrid simulation model for photovoltaic generators and storage units is presented in (Mazhari et al. 2009). They apply the simulation software AnyLogic and use SD and agent-based modeling. The agents represent the electricity demand of individual households. The heat demand with respect to gas consumption is not considered. The households are not equipped with regenerative energy systems and are not separated in components. They cannot cooperate in a local grid. Their solar insolation model is the basis for the model used in this paper.

A component based approach of the households is described in (Molderink et al. 2009) and used as a guideline for the approach presented in this paper. The houses are not equipped with renewable sources. A new version of the model in (Bakker et al. 2010) allows the export of energy but there is no photovoltaic system implemented. Discrete simulation is used for the analysis of both versions and the simulator is built directly in the C++ programming language.

Based on a set of equations with a discrete time parameter, a discrete simulation model for a  $\mu$ CHP system is described in (Houwing, Negenborn, and De Schutter 2011). This model is used for the construction of the hybrid simulation model of the  $\mu$ CHP and the gas heating in this paper. Their models for electricity and heat demands are also used in this paper.

(De Durana and Barambones 2009) describe another microgrid simulation model done with the AnyLogic simulation software in which a stochastic wind model and a centralized control is applied, the model however does not provide details about houses and their components. In (Kremers et al. 2011) the stochastic wind model is refined. In our paper we concentrate on photovoltaics as regenerative source and do not consider wind, although this would be an interesting extension.

Liquid organic hydrogen carriers are described in (Teichmann et al. 2011) and the storage concept for the energy carrier carbazole as an energy storage with high capacity is used in this paper.

### 3 BASIC CONCEPTS

In this section we describe the basic concepts used for the hybrid simulation framework. It addresses the simulation of complex energy systems on a high level. Therefore the components are described mainly by quantities such as power output and energy flow.

#### 3.1 Hybrid Simulation

For example Figure 1 shows on the left side the parameters of a fuel cell model where the fuel cell has a maximum power output (`ramp_max`), a minimum power output (`ramp_min`), and can increase or decrease the power output with certain maximum and minimum rates (`rate_up` and `rate_down`). Within these boundaries the fuel cell can follow a power demand.

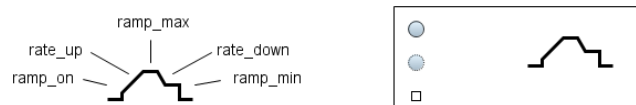

Figure 1: Fuel cell parameters (left) and hybrid simulation fuel cell component (right)

Additionally, a fuel cell can be switched on and off and has therefore an inner state. If it is switched off it can go to the state delay and reduce the generated electricity according to `rate_down`. The fuel cell can be switched off by sending a switch off message. The fuel cell receives this message over its message port and can react appropriately.

For the continuous dynamics part of the model the concept of system dynamics is used (Figure 2 left). The discrete event simulation part is represented by statecharts (Figure 2 right). The message passing is realized by ports. Through these ports, messages can be exchanged between components.

For the implementation of this hybrid simulation model the simulation software AnyLogic (XJ Technologies Company Ltd. 2012) is used. It allows the graphical construction of hybrid simulation models which can be enriched by Java code blocks. With its active object paradigm it supports the development of component based simulation frameworks. E.g., the component consisting of the system dynamics model and the statechart model of Figure 2 and of a message port is shown in Figure 1 on the right side.

#### 3.2 Component Interfaces

The described components can be joined to new components. The fuel cell and a heat storage component, together with a gas burner, can be combined to a  $\mu$ CHP. Such composed components can then be used for a house component, and several different house components can be connected to an electricity net and a gas net component. This means that the system dynamic parts of the houses are connected to the system dynamic parts of the networks. A house can import gas (`IGasIntImp`), import (`IElectricityIntImp`) and export electricity (`IElectricityIntExp`) with varying prices (`IElectricityExtPrice`), and store (`IElectricityEx-`

tImp) and deliver stored (IElectricityExtExp) electricity. The different roles of a house are realized as interfaces (Figure 3), encapsulating the system dynamics parts. These interfaces are important for the flexibility of the simulation framework.

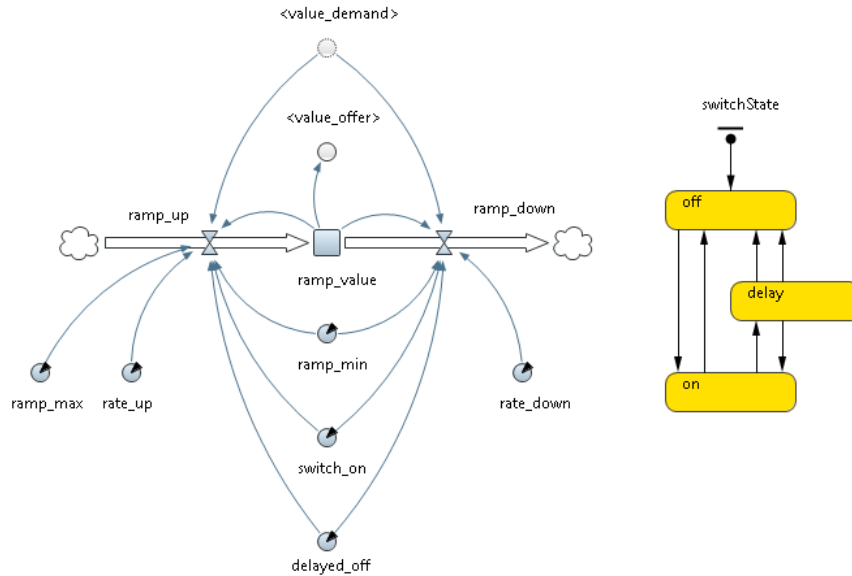

Figure 2: System dynamics and statechart model of a fuel cell with AnyLogic

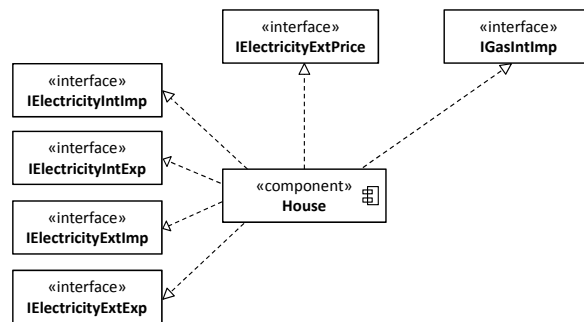

Figure 3: UML component diagram showing the provided interfaces of a house component

### 3.3 Dynamic System Dynamics

The message ports are used for bonding the system dynamics parts of different components (Figure 4 right). The connections are joined during the runtime of the simulation; specifically, at the start of the simulation. At this time all houses send messages to the net with information about their implemented interfaces. This allows the easy connection of several hundreds of houses on the system dynamics level, without the need for constructing them during the design time of the model, as is shown in Figure 4 on the left. We call this modeling approach “dynamic system dynamics”.

## 4 BASIC COMPONENTS

With the techniques described in the previous section we can now construct several basic components as building blocks for houses. The components can be divided into demand components, supply components, and storage components. For the energy networks there are two net components.

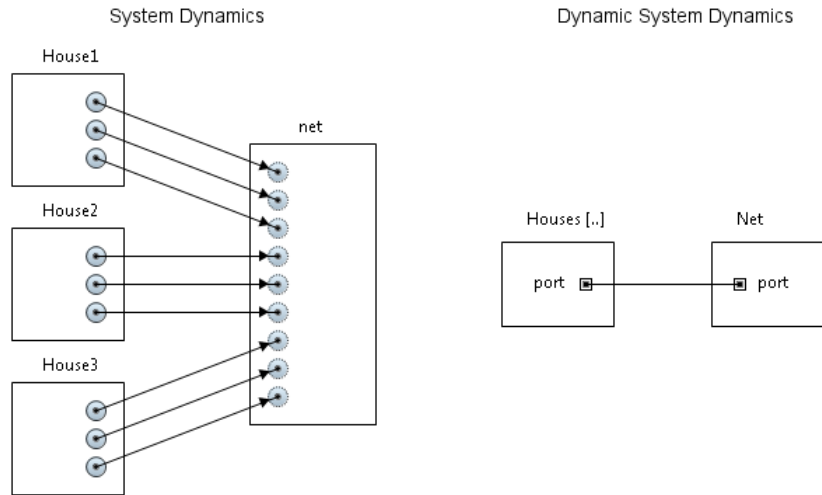

Figure 4: House-net model for connecting the system dynamics interfaces

#### 4.1 Demand Components

The heat demand and electricity demand components (Figure 5) are designed as described in (Houwing, Negenborn, and Schutter 2011) and (Weijnen and Houwing 2010). For the electricity demand and the heat demand profiles of the energy consumption of households are used. From these profiles values are sampled and superimposed with stochastic functions to model the stochastic behavior of a single household. In AnyLogic the profiles are stored as table functions (Figure 6).

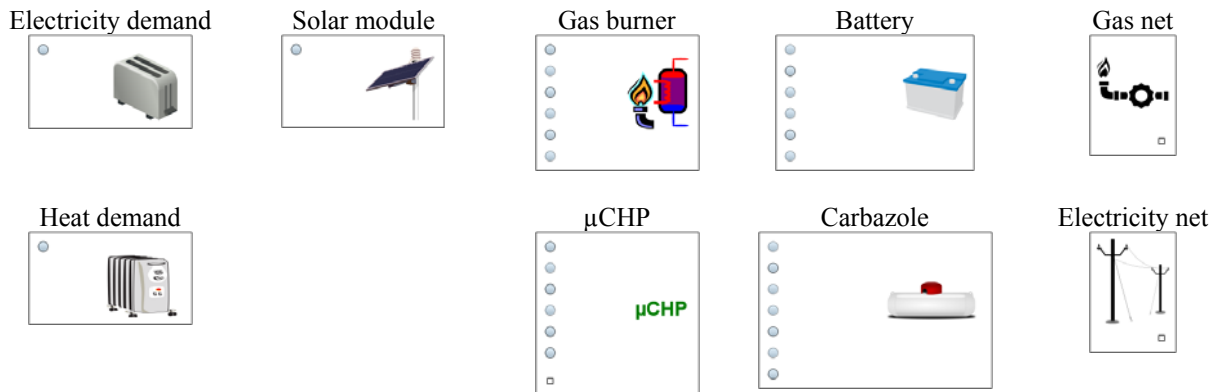

Figure 5: Basic components

#### 4.2 Supply Components

For the solar module model (Figure 5), a solar insolation model is required. This model is implemented according to (Mazhari et al. 2009). Weather profiles are used and superimposed with stochastic functions. The solar modules provide electricity. Heat is generated by a gas burner and stored in a heat storage (Figure 5). A more complex component is that of a  $\mu$ CHP (Figure 5). The  $\mu$ CHP uses gas and delivers heat and electricity. For the model we followed (Houwing, Negenborn, and De Schutter 2011). In this paper they have presented a  $\mu$ CHP with a fuel cell, a gas burner and a heat storage. We use the described heat driven operation mode.

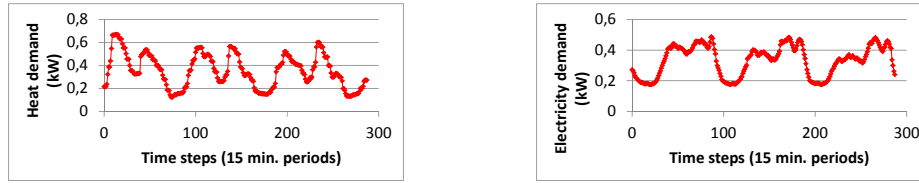

Figure 6: AnyLogic table functions of three days (summer) for heat (left) and electricity (right) demand

### 4.3 Storage Components

As one storage component a battery model is implemented (Figure 5). The other storage component is a first model of a liquid energy carrier system using carbazole (Teichmann et al. 2011). Such a system can bind hydrogen to the liquid with a catalyzer. The hydrogen is produced by a fuel cell consuming electricity. This process generates heat, which is stored in a heat storage. The hydrogen can be extracted from the carbazole with a second catalyzer. This process needs heat. Most of the heat can be delivered from the fuel cell by burning the hydrogen and producing electricity (as a by-product).

### 4.4 Net Components

The gas net component delivers gas, the electricity net component delivers electricity (Figure 5). The latter can export electricity to the superordinate power network or distribute it to other connected homes. The presented components will be used in the next section for the construction of house components.

## 5 RENEWABLE ENERGY EXAMPLES

In this chapter we describe three different house types. They are composed of the basic components described in the previous section. Every house consists of a heat demand and electricity demand component, a photovoltaic cell together with a solar irradiation component, a heat generation and storage unit, and an electricity storage component. The heat generation and the electricity storage unit can vary from house to house. The parameters are given in Table 1.

For the analysis of the homes they are connected to an electricity net and a gas net. The gas net delivers gas for €0.07 per kWh and the electricity net delivers electricity for €0.25 per kWh. The latter can receive energy for €0.195 per kWh if it is produced by the solar cells.

The electricity from the solar cells has priority over imported energy with respect to the electricity demand of a house. When the generation exceeds the demand, the energy is stored. Only when the storage is full, energy is exported to the net. If the demand exceeds the generation, the energy is drawn from the battery. With a dead battery, energy is imported from the net.

The simulated time begins on 1/1/2012 and ends on 1/1/2022. The efficiency of a house is the fraction of exported or consumed energy compared to the imported and generated energy. The profit is calculated as follows. As a reference, the costs (for gas and electricity) of a conventional house without photovoltaics and storages is computed. The shown profit is the difference between this reference value and the costs for a house with such components. Investment costs are not considered.

Table 1: Parameters

Efficiency		Size and volume		Maximum power	
Solar module	0.1	Solar module	20 m <sup>2</sup>	Battery	1 kW
Solar park	0.15	Solar park	1600 m <sup>2</sup>	Gas burner	4 kW
Battery	0.9	Heat storage	120 l	Carbazole	20 kW
Gas burner	1.0	Carbazole storage	5000 l		
Fuel cell	0.45				
Electricity net	0.97				

### 5.1 Battery House

The first house (Figure 7) is equipped with a solar module, a battery, and a gas burner for heat generation. The toaster symbol represents the model for the electricity demand and the radiator stands for the heat demand (see Ch. 4.1). There is no energy flow between the electricity section and the heat section.

The simulation model of the battery house connected to the electricity and gas net is given in Figure 8. As shown in Figure 9, the efficiency is about 99%. The profit is €3333 after 10 years (excluding investment costs). 97% of the solar energy is consumed and only 3% is exported. The photovoltaic system provides 37% of the electricity needed. The rest has to be imported.

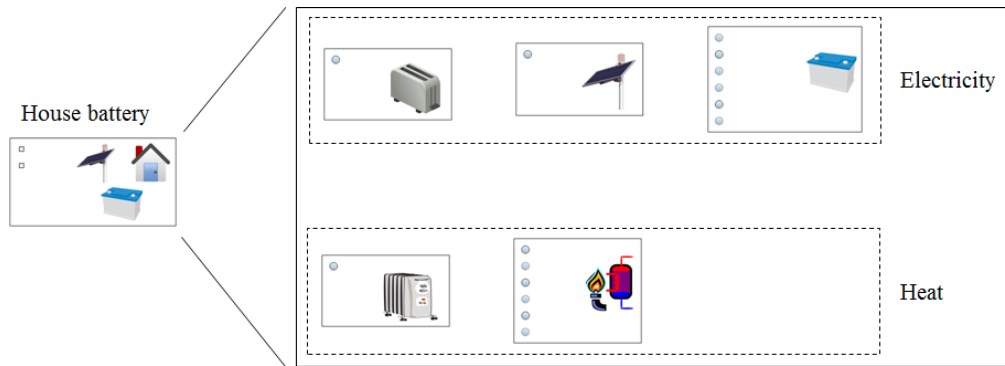

Figure 7: Electricity and gas components of the battery house

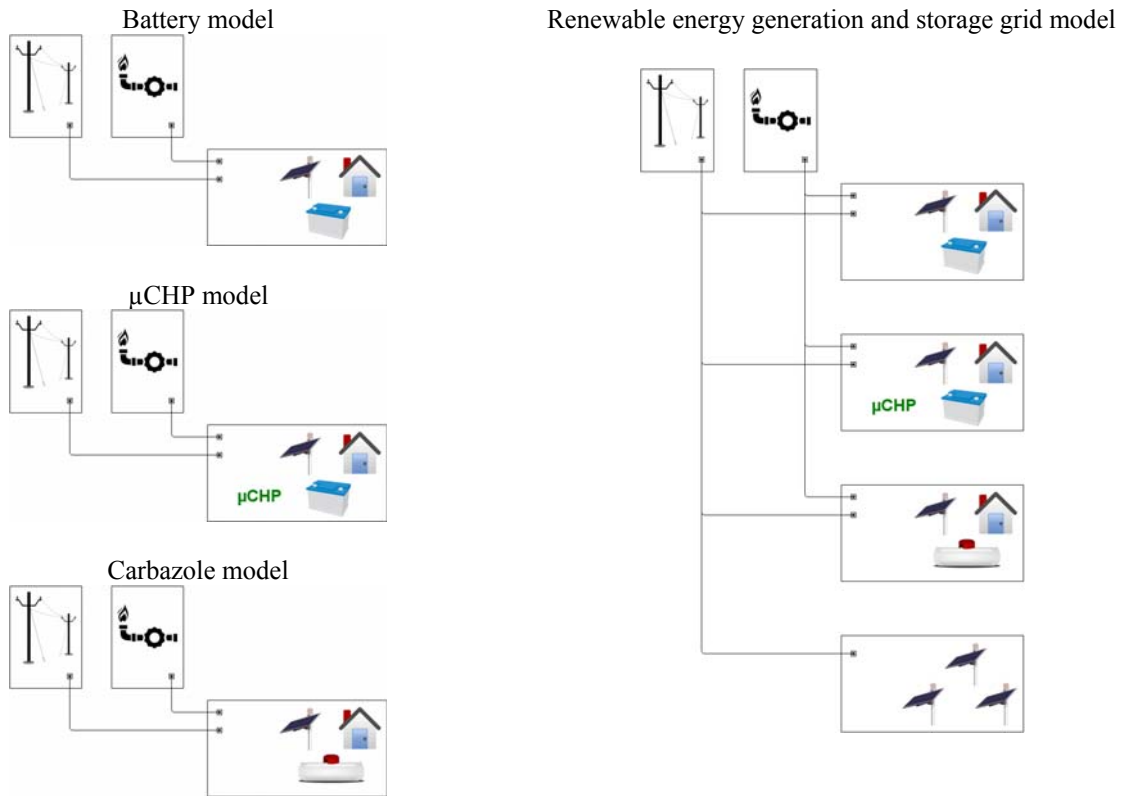

Figure 8: The left column shows the simulation models of the battery, the  $\mu$ CHP, and the carbazole house. The right column shows a storage grid example (see Ch. 6 for details).

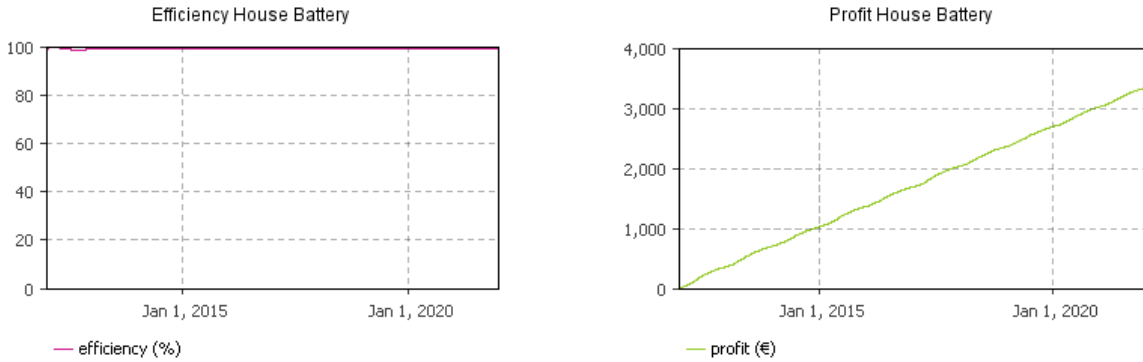

Figure 9: Simulation results for the battery house, profit shows savings compared with conventional house, investments excluded

### 5.2 $\mu$ CHP House

The  $\mu$ CHP house (Figure 10) is equipped with a solar module, a battery, and a  $\mu$ CHP for electricity and heat generation. The  $\mu$ CHP of the gas section delivers the produced electric energy to the electricity section. The compensation for excess electricity fed into the grid produced by the  $\mu$ CHP is €0.09 per kWh.

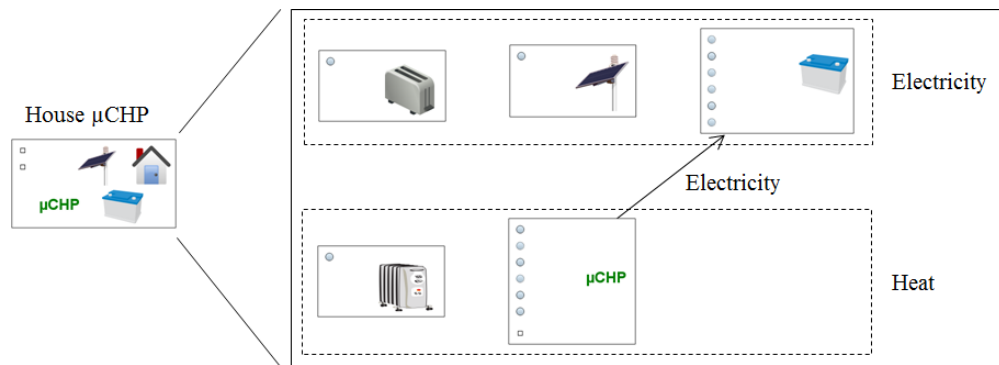

Figure 10: Electricity and gas components of the  $\mu$ CHP house

The simulation results of the  $\mu$ CHP house simulation model are given in Figure 11. Because the  $\mu$ CHP generates electricity in the process of generating heat for the heat demand of the house, 51% of the production of the photovoltaic generator is exported. This export has priority over the export of electricity from the  $\mu$ CHP due to the fact that it makes more money. A total of €7523 will be earned. The internal consumption of  $\mu$ CHP and photovoltaic energy amounts to 94% and the efficiency of the system is 90%.

### 5.3 Carbazole House

The carbazole house (Figure 12) has no battery but a carbazole storage unit instead. This unit delivers heat during the electricity storage process. This heat is stored into the heat storage of the gas burner.



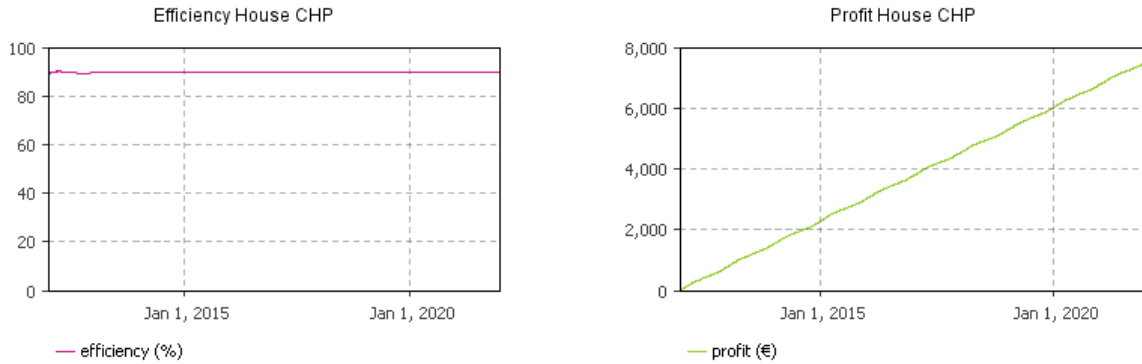

Figure 11: Simulation results for the  $\mu$ CHP house, profit shows savings compared with conventional house, investments excluded

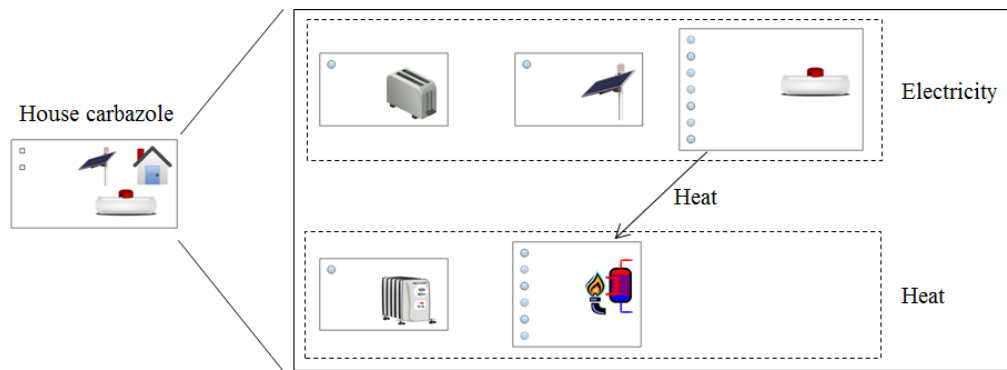

Figure 12: Electricity and gas components of the carbazole house

The simulation model of the carbazole house of Figure 8 is now analyzed. The efficiency is 99% and therefore as good as that of the battery house model but with €2481 the profit is less (Figure 13). 0% of the solar energy is exported because the carbazole storage unit can store it all. It also requires less gas due to the fact that the storage of electricity generates heat. But in return, more expensive electricity has to be imported. The own production of electricity covers only 24% of the internal electricity consumption.

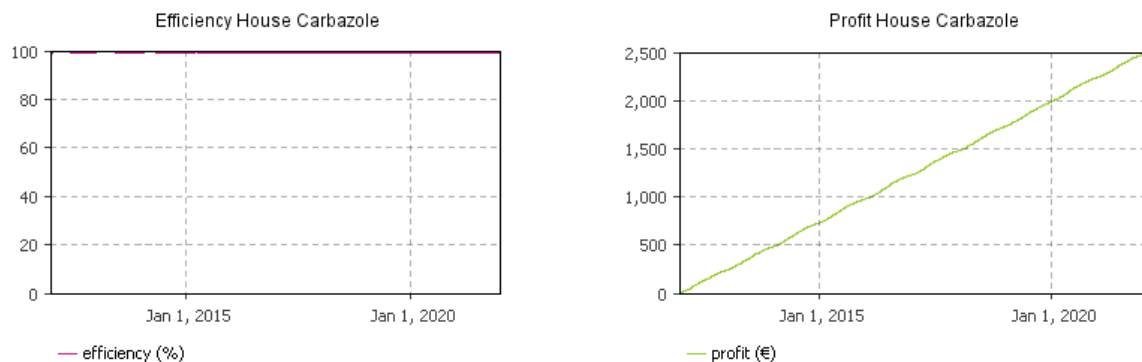

Figure 13: Simulation results for the carbazole house, profit shows savings compared with conventional house, investments excluded

## 6 STORAGE GRID EXAMPLE

From the components described above now a simulation model of a renewable energy generation and storage grid can be constructed. The network consists of ten components of the type battery house, ten components of the type  $\mu$ CHP house, and ten components of the type carbazole house. In total 30 houses are connected to the components electricity net and gas net. This can be done easily because of the dynamic system dynamics concept which allows the connection of several houses of the same type - modeled as an array - in an easy way. Each of these arrays must be connected only once to the port of the respective network component. To complement this, there is a solar park covering an area of 1600 m<sup>2</sup>, which feeds electricity into the grid. The simulation model is shown in Figure 8 on the right side.

The buildings and the solar farm act as a local grid. The solar park will produce energy for the connected houses at a cost of €0.2 per kWh. It does not have a power reservoir. If more energy is produced than consumed, it will be stored in the energy storages of the houses for free. If the energy storages are full, the current is fed into the superordinate power network at a price of €0.195 per kWh. If a home produces more energy than it needs, then at first the internal storage is filled. If it is full, the energy is delivered to the grid and sold either to other houses for €0.2 per kWh or in case of excess of energy stored free of charge in their energy storage systems. Exports to the superior power network in case of full energy storages is rewarded with €0.195 per kWh.

Before a house imports energy from the grid, at first the own storage is emptied. Then excess or stored energy is imported from the grid for €0.2 per kWh. If there is not enough energy in the grid available, energy can be purchased from the superior electricity net at a cost of €0.25 per kWh. The gas price is €0.07 per kWh.

The simulated time begins on 1/1/2012 and ends on 1/1/2022. At the beginning all energy storages are empty. The battery house (Figure 14) increases its profit by €1980, compared to the single house scenario, because excess energy from the grid can be stored and used later. The solar park and the local distribution of energy lead to an electricity import from the superordinate network of nearly 0%.

The  $\mu$ CHP house may benefit only marginally with €435, as shown in Figure 14. Almost all of the electricity demand can be met by domestic production. The profit will increase after the ten simulated years due to the expired compensation for electricity fed into the grid.

The increase in profit of €10,969 (Figure 14) suggests that electricity from the grid is stored in the carbazole unit of the carbazole house. This process produces such an amount of heat that the heat storage can hold no more. This waste of heat is the reason for the efficiency of approximately 60%. The efficiency oscillates after the fill level of the carbazole has found its operating point.

## 7 CONCLUSION AND FUTURE WORK

In this paper we presented a simulation framework - based on AnyLogic - for the rapid prototyping of renewable energy generation and storage grids. We have taken several methods from the literature for modeling of electricity demands, solar irradiation, class based components and combined them with the dynamic system dynamics approach. This approach allows an easy connection of the system dynamics parts of the simulation components. As components there are among others a heat and an electricity demand model, a solar irradiation model, a photovoltaic module, a battery, a gas burner, a  $\mu$ CHP model, and an early model of a storage unit based on the liquid energy carrier carbazole. We then combined these basic components to model households with renewable energy generation and storage units. With the house models and models for the electricity net and the gas net a simulation model of a renewable energy generation and storage grid was constructed and analyzed. We have shown the efficiency and profit of different house types acting together in a local grid. It is thus possible to calculate savings of regenerative houses compared to conventional houses and to check whether the necessary investments pay off.

We plan to enrich the simulation framework by a network model which can be used for the communication between the components to allow the construction of smart grid models. In addition, we want to implement more types of components.

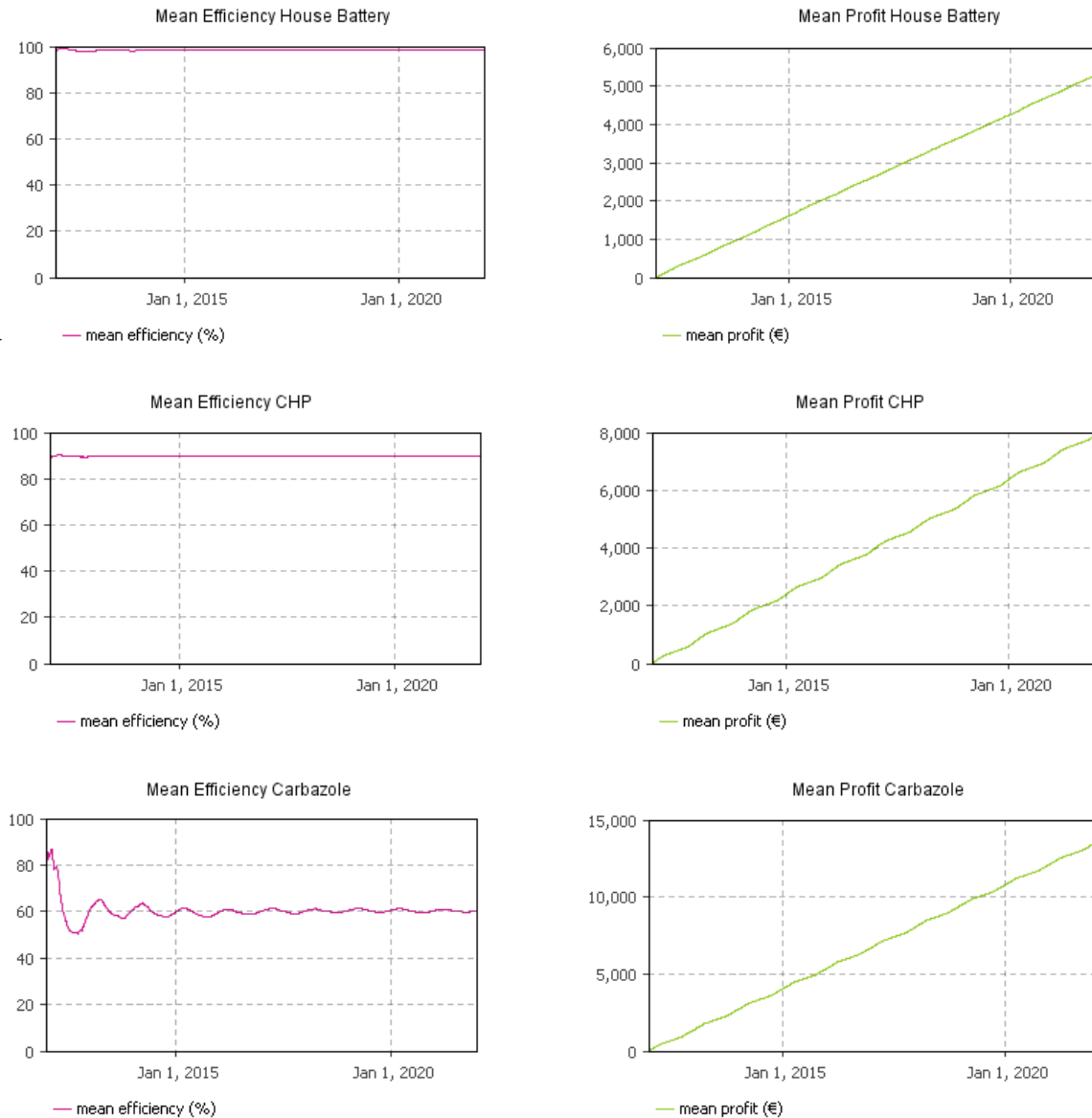

Figure 14: Simulation results for the renewable energy generation and storage grid example, profit shows savings compared with conventional houses, investments excluded

**REFERENCES**

Bakker, V., A. Molderink, M. G. C. Bosman, J. L. Hurink, and G. J. M. Smit. 2010. "On Simulating the Effect on the Energy Efficiency of Smart Grid Technologies." In *Proceedings of the 2010 Winter Simulation Conference*, Edited by B. Johansson, S. Jain, J. Montoya-Torres, J. Hukan, and E. Yücesan, 393-404. Baltimore.

De Durana, J. M. G., and O. Barambones. 2009. "Object Oriented Simulation of Hybrid Renewable Energy Sytems Focused on Supervisor Control." *IEEE Conference on Emerging Technologies & Factory Automation*, 1-8.

Houwing, M., R. R. Negenborn, and B. De Schutter. 2011. "Demand Response With Micro-CHP Systems." *Proceedings of the IEEE*, Vol. 99, No. 1: 200-212.

- Kremers, E., N. Lewald, P. Viejo, J. M. G. De Durana, and O. Barambones. 2011. "Agent-Based Simulation of Wind Farm Generation at Multiple Time Scales." Wind Farm - Impact in Power System and Alternatives to Improve the Integration, Dr. Gastn Orlando Suvire (Ed.), InTech.
- Mazhari, E. M., J. Zhao, N. Celik, S. Lee, Y.-J. Son, and L. Head. 2009. "Hybrid Simulation and Optimization-Based Capacity Planner for Integrated Photovoltaic Generation with Storage Units." In *Proceedings of the 2009 Winter Simulation Conference*, Edited by M. D. Rossetti, R. R. Hill, B. Johansson, A. Dunkin, and R. G. Ingalls, 1530-1540. Austin.
- Molderink, A., M. G. C. Bosman, V. Bakker, J. L. Hurink, and G. J. M. Smit. 2009. "Simulating the Effect on the Energy Efficiency of Smart Grid Technologies." In *Proceedings of the 2009 Winter Simulation Conference*, Edited by M. D. Rossetti, R. R. Hill, B. Johansson, A. Dunkin, and R. G. Ingalls, 1530-1540, Austin.
- Teichmann, D., W. Arlt, P. Wasserscheid, and R. Freymann. 2011. "A Future Energy Supply Based on Liquid Organic Hydrogen Carriers." *Energy & Environmental Science*. 4: 2767-2773.
- Weijnen, M.P.C. , and M Houwing, 2010. "Smart Heat and Power: Utilizing the Flexibility of Micro Cogeneration". Next Generation Infrastructures Foundation 2010-03-05.
- XJ Technologies Company Ltd. 2012. "AnyLogic." Accessed March 22. <http://www.xjtek.com>.

## AUTHOR BIOGRAPHIES

**PETER BAZAN** studied Computer Science at the University of Erlangen, Germany and obtained his Masters Degree (Diplom) 1996 with a thesis on the area of performance modeling. He worked a couple of years as a consultant for industry projects before he went into business for himself. In addition to his business he worked for the Performance Modelling and Process Control research group at the University Erlangen-Nuremberg. Since 2001 he worked in various positions at the Department of Computer Science (computer networks and communication systems) at the University Erlangen-Nuremberg, Germany. He is mainly interested in the analysis of renewable energy systems and smart grids based on hybrid simulation. His e-mail is [peter.bazan@cs.fau.de](mailto:peter.bazan@cs.fau.de).

**REINHARD GERMAN** received a diploma in computer science in 1991, the PhD degree in 1994, and the habilitation degree in 2000 from the Computer Science Department, Technical University of Berlin. Thereafter, he joined the Department of Computer Science at the University Erlangen-Nuremberg. First, he was an associate professor (system simulation), then he became a full professor in 2004 (computer networks and communication systems), and served as head of the department and as dean of the faculty of engineering. His research interests include performance and dependability analysis of networked systems based on numerical analysis, network calculus, discrete-event simulation, measurements, and testing. Vehicular communications, smart energy systems and healthcare constitute major application domains. His e-mail is [german@cs.fau.de](mailto:german@cs.fau.de).